

# Investigation of the heat generator similar to Rossi reactor

A.G. Parkhomov<sup>1</sup>

**Abstract**—This paper describes development and tests of a device that is similar to the well-known high-temperature Rossi reactor. The experiments confirmed that at the temperature about 1100°C and more this device produces more energy than it consumes. Performed measurements demonstrated no ionized radiation above the background level from the working reactor.

The report of experts, who observed the work of the high-temperature Rossi reactor in Lugano [1], [2], indicated that the reactor might represent a ceramic tube, sealed by a heat-resisting cement, with a nickel powder and lithium aluminum hydride addition. In order to initiate the reaction it is necessary to heat the tube up to 1200 – 1400 °C. Taking into account this report and making several assumptions, a device has been developed, which can be viewed as analogous to the high-temperature Rossi reactor.

## I. DESIGN OF THE DEVICES

Alumina ceramic tubes of 120 mm length with the outer diameter of 10 mm and the inner diameter of 5 mm have been used (Fig. 1). Nichrome wire was wound on the tube as an electric heater. 1 g of Ni powder with 0.1 g  $Li[AlH_4]$  was placed inside the tube. The thermocouple contacted the outer surface of the tube. Both tube ends were sealed with the heat-resisting cement. The entire reactor's surface was also coated by this cement.

## II. MEASUREMENT OF HEAT OUTPUT

The measurement method used by experts during the Rossis reactor test seems to be too complicated. In the described experiment we used another approach, based on the amount of water boiled away. This method is verified multiple times in various experiments, including experiments with plasma electrolysis.

The reactor is placed in a closed metal vessel (Fig. 2), which is submerged in the water. Some amount of water is steamed away during the reactor's work. Measuring the evaporated water and using the known heat of vaporization (2260 kJ/kg), allows calculating the produced heat. The heat loss through the thermal isolation can also be calculated by considering the cooling rate after the reactor is switched off.

<sup>1</sup> alexparh@mail.ru.

The reactor was placed either uncovered on the alumina supports or immersed into alumina powder in a metal box. The second approach requires the 2-3 times less power to heat up the reactor, but this operating mode of the reactor is less stable.

## III. EQUIPMENT FOR HEATER POWERING AND DIAGNOSTICS

Fig. 3 shows the equipment used for heater powering, the measurement and control of consumed power, the temperature measurement and the registration of possible nuclear radiation.

The electric power in the first experiments was taken directly from the electric network (220V) by using a thyristor regulator. In later experiments the transformer with switching coils was utilized (Fig. 4). The coils are switched manually or automatically by the regulator, which was controlled by the thermocouple sensor. When the temperature rises above a threshold, the regulator switches to the lower voltage. When the temperature decreases below another threshold, the voltage was increased again. It allows long-time working at a predefined temperature and operating the reactor in a stable mode. To measure the consumed power we used a voltmeter, amperemeter, and watt-hour meter that transmits data to the computer. The program records the received data in real time.

For monitoring a radiation level we used the Geiger-counter SI-8B, the dosimeter DK-02 and neutron-activation technique with indium. The counter SI-8B has thin mica input window, that allows detecting not only beta and gamma radiation, but also alpha particles and soft x-rays. The dosimeter DK-02 is a capacitor-based ionization chamber with the measurement range of 200 mR (beta and gamma rays).

Indium plates, submerged into calorimeter water, are used for neutron monitoring. To measure indium activity we used two Geiger-counters. Impulses from these counters are registered by the computer. Large surface of indium plate (18  $cm^2$ ) allows registering slow neutrons that have the flux density more than 0.2 neutron/ $cm^2$ .

Besides this, the computer registered impulses from the counter, mounted on the reactor's cap and data from watt-hour meter. Another computer with the connected logger PCLAB-2000 displayed and recorded the reactor's

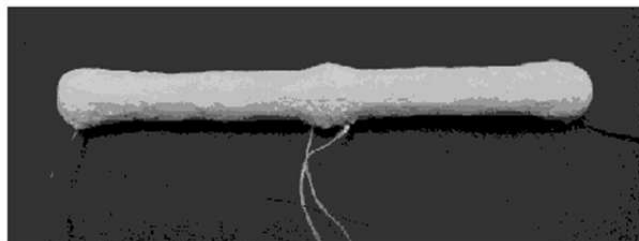
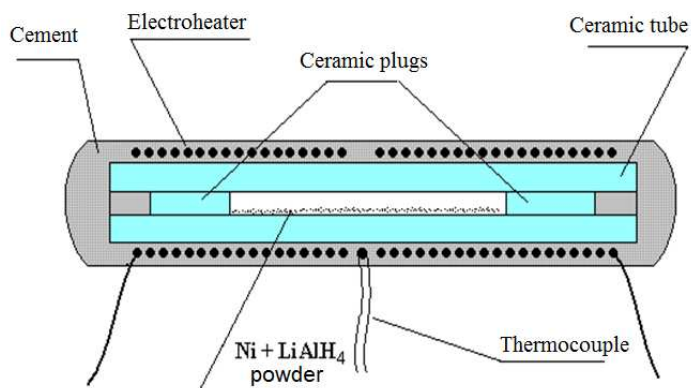

Figure 1. (Right) scheme of the device and (left) the picture of the reactor before operation.

temperature and a signal proportional to the counter rate from SI-8B.

#### IV. TEMPERATURE CHANGES DURING THE HEATING

Below we show the dynamics of temperature in two experiments on 20.12.2014 and 18.01.2015.

**The experiment on 20.12.2014.** We have slowly changed the heater power from 25 to 500 W (Fig. 5). The temperature of 1000°C was achieved 5 hours after the start of heating. This diagram shows also the counter rate of the Geiger-counter SI-8B. It is well visible that the radiation remains on the background level during the entire heating process. The dosimeter DK-02 did not measure the radiation above the accuracy limit (5 mR) during the experiment. No noticeable activation of indium was also detected.

Fig. 6 shows a dynamics of temperature changes at the heating power of 300, 400, 500 W. It should be noted that the temperature is gradually increasing, especially in the

last interval, at a constant heating power. It indicates generating the heat by the reactor additionally to the applied electrical heating. The interval with a maximal temperature undergoes some oscillations and ends up with a drop of temperature because the electrical heater was burned out. After that the temperature remained at 1200°C during 8 min, and only then decreased to initial level. It needs to point out that the reactor at this time produced the heat on a kilowatt level without electro-heating.

**The experiment on 18.01.2015.** The reactor was placed uncovered on the alumina supports during the first stage of experiment. The maximal temperature of 900°C was reached with electro-heating at the 450 W power. Then the reactor was coated by a heat insulation from alumina powder. With the constant power of 160 W the temperature is increased from 600 to 1000°C. Then the reactor was operated at the temperature of about 1080°C.

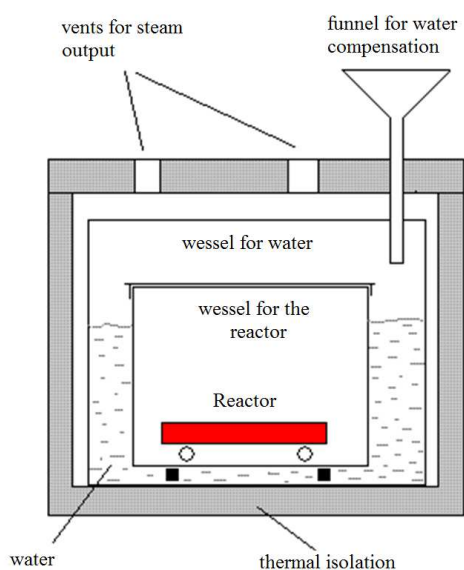

Figure 2. Scheme of the calorimeter with evaporized water.



Figure 3. Equipment for heater powering and diagnostics. Left to right on the upper shelf: thermocouple signal amplifier with power regulator, the data logger, the computer for recording temperature and rate of Geiger counter, device for measuring the rate of Geiger counting. Left to right on the lower shelf: amperemeter, reactor's power source, voltmeter, watt-hour meter, power line switch.

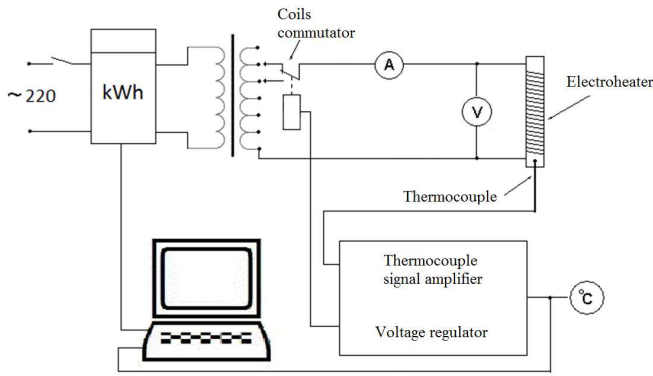

Figure 4. Scheme of powering and the electro-heater power regulation.

When we tried to increase the temperature, the heater was burned out.

V. PRODUCED HEAT AND COP CALCULATION

Table I  
COP CALCULATION FOR THE EXPERIMENT ON 20.12.2014.

Average temperature of the mode	°C	970	1150	1290
Mode duration	min	38	50	40
Electroheating power	W	300	394	498
Electroenergy input	kJ	684	1182	1195
Mass of the evaporized water	kg	0,2	0,8	1,2
Energy to heat up to boiling point	kJ	63	251	377
Energy to evaporation	kJ	452	1808	2712
Heat leakage through thermal isolation	W	70	70	70
Heat leakage through thermal isolation	kJ	159	210	180
Full energy outcome	kJ	674	2269	3269
COP		<b>0,99</b>	<b>1,92</b>	<b>2,74</b>

The calculations shown in Table I are made for three reactor's operation modes: with the temperature about 1000°C, 1150°C, and 1200-1300°C. With the temperatures of 1150°C and 1200-1300°C the produced heat essentially exceeds the consumed energy. During operating in these modes (90 min) about 3 MJ or 0.83 kWh was produced. Such energy can be produced by burning 70 g gasoline.

Table II

COP CALCULATION FOR THE EXPERIMENT ON 18.01.2015.

Thermal isolation		Air	Alumina
Average temperature of the mode	°C	800	1080
Mode duration	min	90	38
Electroheating power	W	252	144
Electroenergy input	kJ	1276	323
Mass of the evaporized water	kg	0,38	0,18
Energy to heat up to boiling point	kJ	32	15
Energy to evaporation	kJ	859	407
Heat leakage through thermal isolation	W	60	60
Heat leakage through thermal isolation	kJ	324	137
Full energy outcome	kJ	1215	559
COP		<b>0,95</b>	<b>1,73</b>

The calculations shown in Table II are made for two operating modes: with the temperature about 800°C (the reactor is uncovered) and with the temperature about 1080°C (the reactor is covered by the alumina powder). In the 1080°C-mode the produced heat also essentially exceeds the consumed energy.

The results shown in Table III are obtained in all experiments during December 2014 and January 2015. Beside experiments with reactors loaded with Ni + Li[AlH<sub>4</sub>] mixture, we also performed control experiments with the 'mock-up reactor' without fuel. In cases of the 'mock-up reactor', as well as in experiments with the fuel below 1000°C, the ratio of produced to consumed energy was near to 1.

*The significant excess heat was observed only when the reactor was loaded with the Ni + Li[AlH<sub>4</sub>] fuel by the temperature about 1100° C and more.*

VI. THE PROBLEM OF UNCONTROLLED LOCAL OVERHEATING

The maximal reached duration of the reactor's work in the excess heat mode is 1.5 hour. The reason of such a short operating time was the structural failures that occur due to local overheating. Image of the reactor in cases of such local overheating is shown in the Fig. 8. The reached temperature was enough to melt alumina, see Fig. 9 (the melting temperature 2040°C).

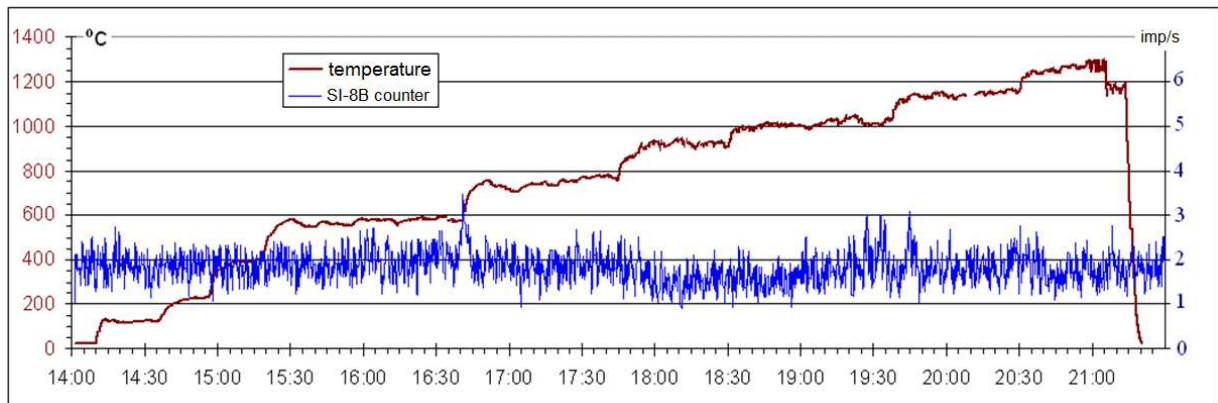

Figure 5. Dynamics of temperature and data from the Geiger counter SI-8B during the experiment on 20.12.2014.

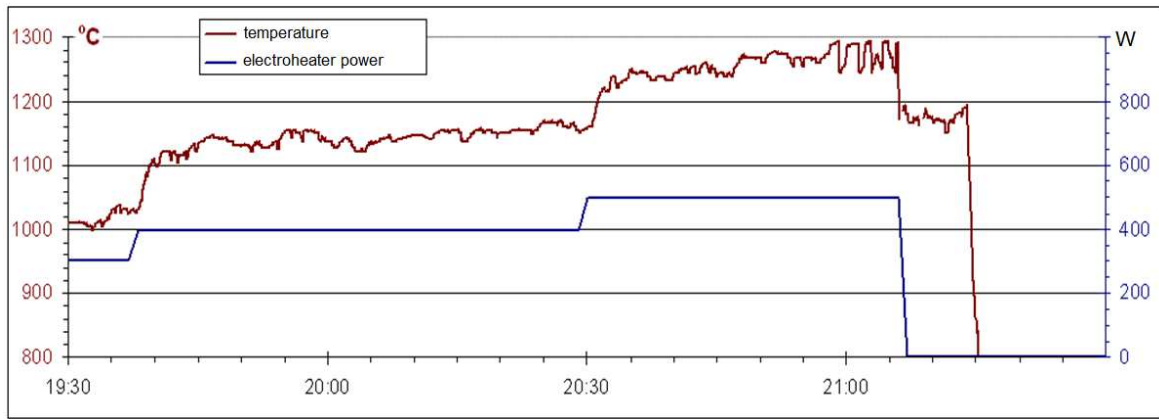

Figure 6. Dynamics of temperature and the power of electro-heating in the high temperature area, the experiment on 20.12.2014.

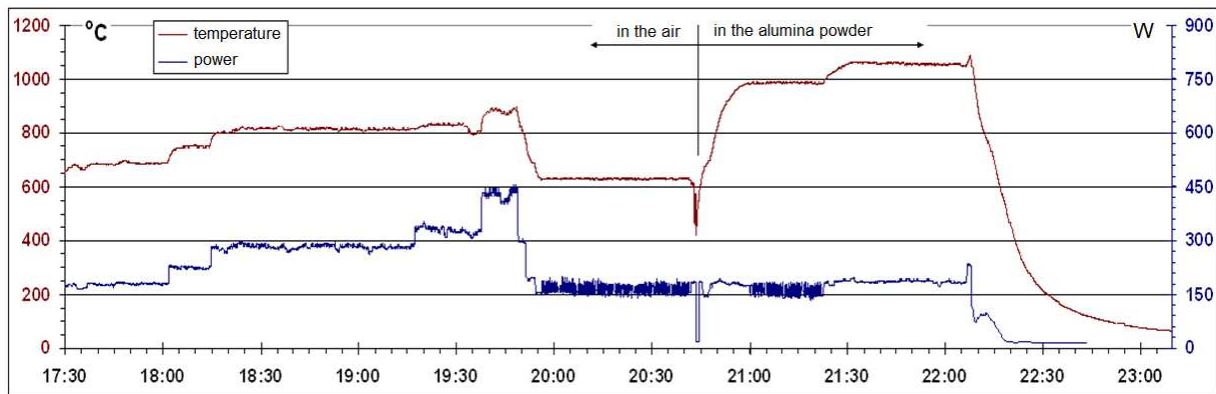

Figure 7. Dynamics of temperature and the power of electro-heating in the high temperature area, the experiment on 18.01.2015.

Table III  
COP IN EXPERIMENTS IN DECEMBER 2014 AND JANUARY 2015

Reactor loaded with fuel					
Date	Temper. °C	Durat. min	Input W	Outcome W	COP
20.12.2014	970	38	301	297	0.99
<b>20.12.2014</b>	<b>1150</b>	<b>50</b>	<b>395</b>	<b>758</b>	<b>1.92</b>
<b>20.12.2014</b>	<b>1290</b>	<b>40</b>	<b>499</b>	<b>1365</b>	<b>2.74</b>
04.01.2015	940	131	304	305	1.00
04.01.2015	1020	75	377	407	1.08
<b>10.01.2015</b>	<b>1080</b>	<b>73</b>	<b>161</b>	<b>284</b>	<b>1.77</b>
18.01.2015	800	90	308	293	0.95
<b>18.01.2015</b>	<b>1080</b>	<b>38</b>	<b>78</b>	<b>135</b>	<b>1.73</b>

Electroheaters					
Date	Temper. °C	Durat. min	Input W	Outcome W	COP
02.01.2015	210	56	211	227	1.07
02.01.2015	470	88	433	414	0.95
02.01.2015	1050	16	928	1035	1.12
21.01.2015	1000	69	297	296	1.00
21.01.2015	1080	43	306	297	0.97
28.01.2015	900	65	95.5	105	1.08
28.01.2015	1100	66	116	116	1.00
28.01.2015	1200	50	151	147	0.97



Figure 8. The local overheating that leads to reactor's failure.

at the temperature about 1100°C and more. There was no ionized radiation above the background level observed while operating the reactor. Neutron flux density was not larger than 0.2 neutron/cm<sup>2</sup>.s.

VII. CONCLUSIONS

Experiments with the replication of the high-temperature Rossi heat generator loaded by a mixture of Ni and lithium aluminum hydride demonstrated that these devices produce more energy than they consume

REFERENCES

[1] G. Levi, E. Foschi, B. Höistad, R.Petterson, L. Tegnér, H.Essén. Observation of abundant heat production from a reactor device and of isotopic changes



Figure 9. Fragment of the reactor, destroyed due to local overheating.

in the fuel. <http://www.sifferkoll.se/sifferkoll/wp-content/uploads/2014/10/LuganoReportSubmit.pdf>.

- [2] A.G. Parkhomov. Report of international committee about Rossi high-temperature heat generator testing (in Russian). *IJUS*, 2(6):57–61, 2014.